

4

3

2

1

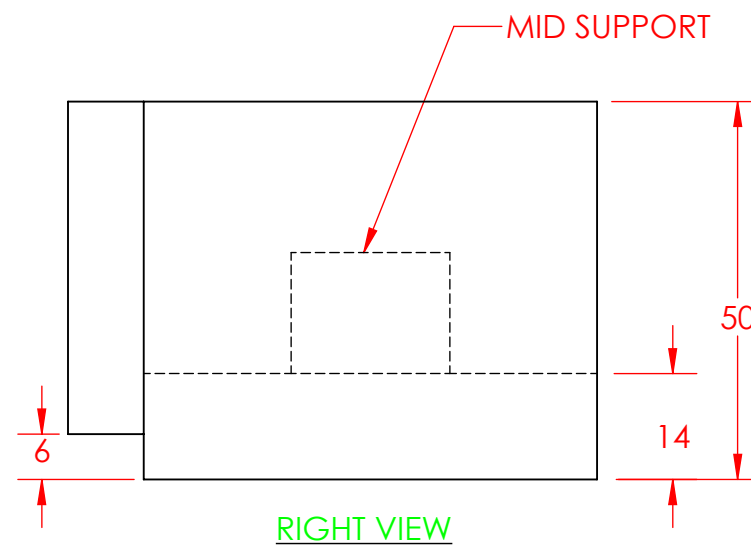
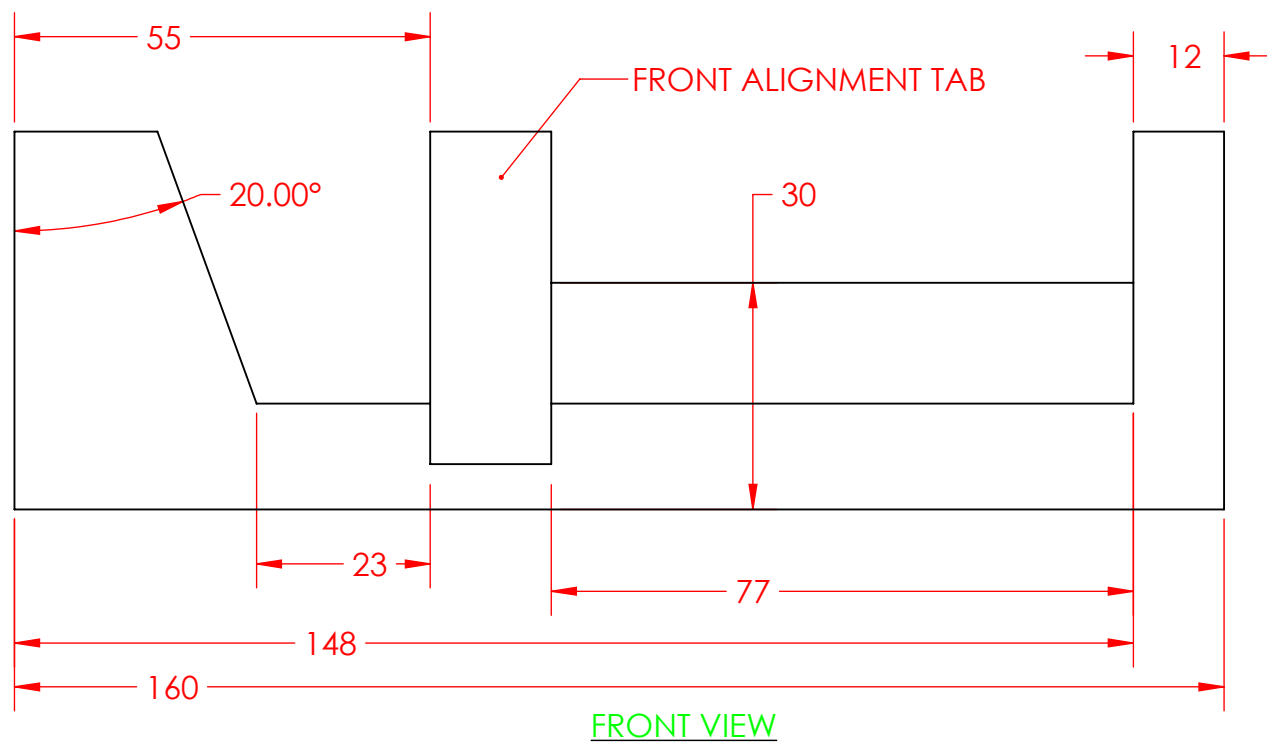
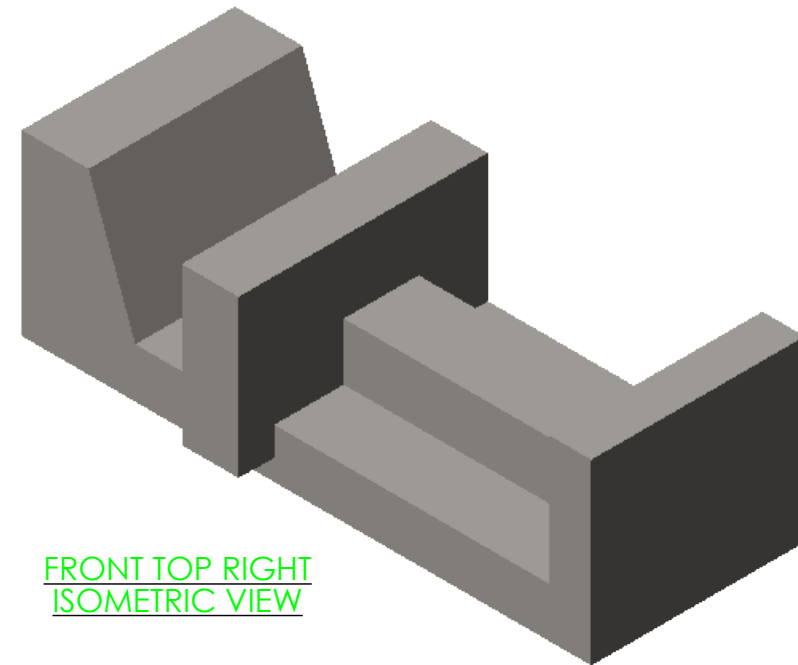
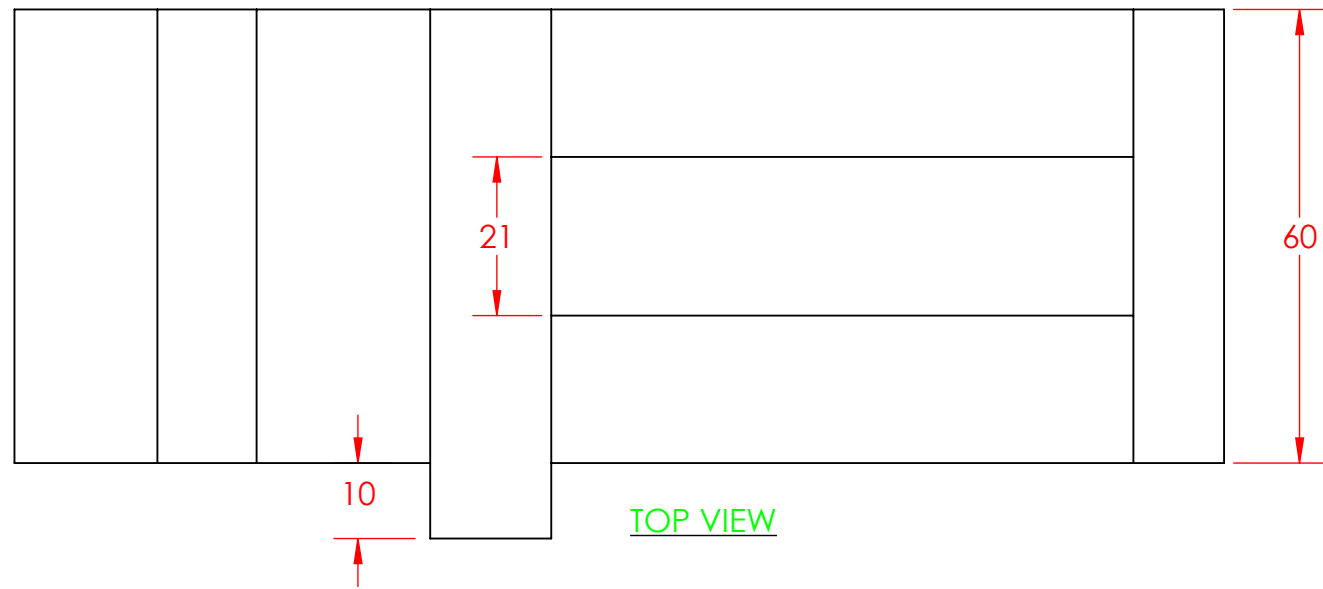

- SHEET NOTES: SUGGEST FEATURE ORDER**
- BASE FEATURE EXTRUDE MIDPLANE PER FRONT VIEW (LOTS OF SKETCH GEOMETRY)
 - MASS = 1823.90 GRAMS
 - CENTER OF MASS: X = 70.59, Y = 18.21, Z = 0.00
 - MID SUPPORT
 - MASS = 2012.76 GRAMS CENTER OF MASS: X = 74.24, Y = 18.57, Z = 0.00
 - FRONT ALIGNMENT TAB
 - MASS = 2064.15 GRAMS
 - CENTER OF MASS: X = 73.96, Y = 18.80, Z = 0.87

PROPRIETARY AND CONFIDENTIAL

THE INFORMATION CONTAINED IN THIS DRAWING AND ANY RELATED MATERIAL IS THE SOLE PROPERTY OF ENTERPRISE DESIGN AND INNOVATIONS. ANY SHARING OF THIS INFORMATION, IN WHOLE OR ANY PART THEREOF IS PROHIBITED WITHOUT EXPRESS WRITTEN CONSENT OF ENTERPRISE DESIGN AND INNOVATIONS.

| | | | | | | | | |
|--------------------------|-----------------|--------------|-----|-----------------|-------|--------------|------------------|--|
| PRESS WEDGE BLOCK | | | | REVISIONS DATE: | ITEM: | NAME | DATE | UNITS IN MILLIMETERS TOLERANCES ARE 0.010 INCHES UNLESS OTHERWISE NOTED |
| EQUIPMENT AIDS | | | | | | DRAWN | CSS 9/30/17 | |
| VARIOUS VIEWS | | | | | | CHECKED | 000 000 | |
| | | | | | | APPV. | 000 000 | |
| | | | | | | MATERIAL | Cast Alloy Steel | |
| SHEET 1 | SHEET SCALE 1:1 | SHEET SIZE B | REV | | | VERSION DATE | 9/30/2017 | |
| | | | | | | | | SHEET FILE NAME: 170930-2016-Press-Wedge-Block |



4

3

2

1

B

B

A

A