

4

3

2

1

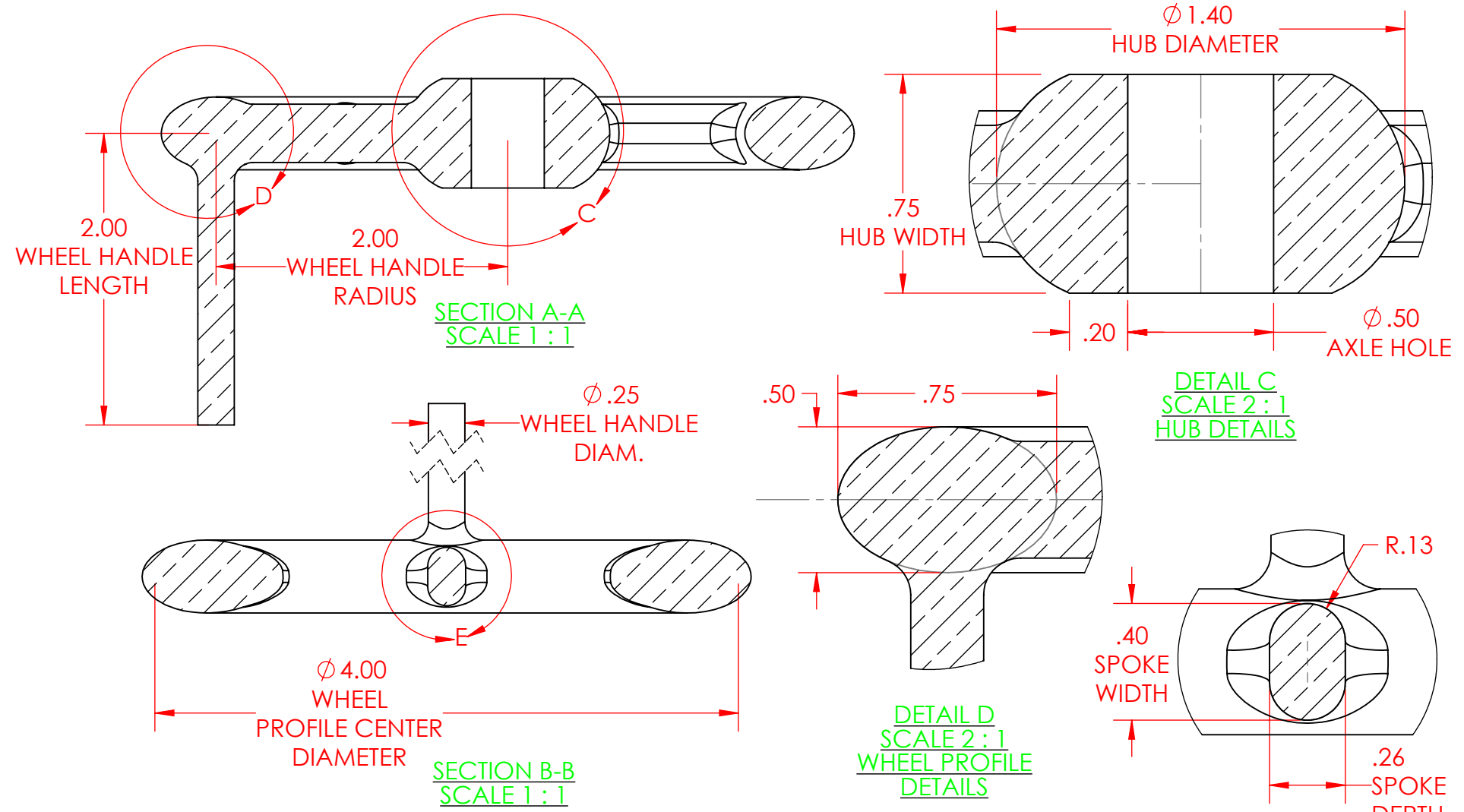
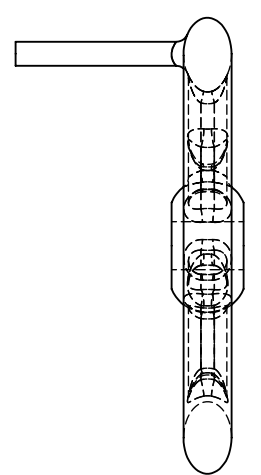
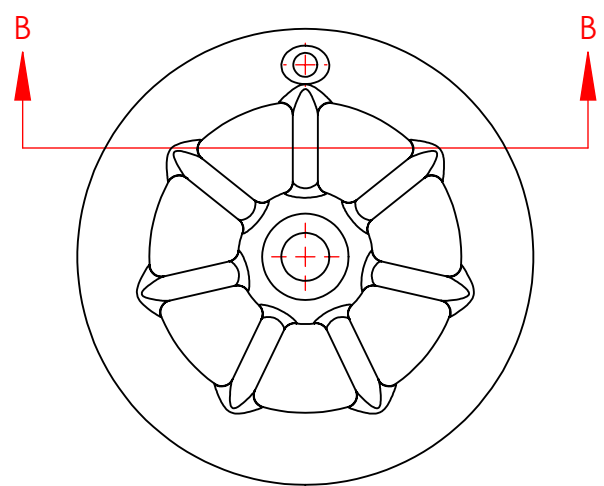
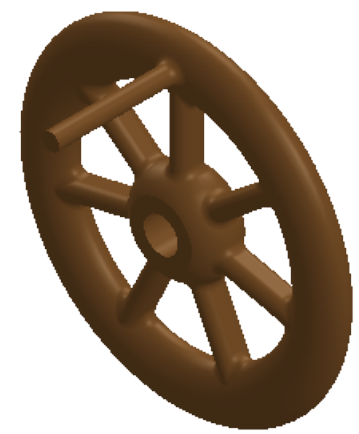
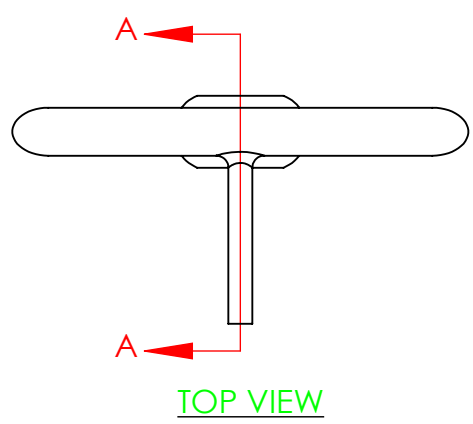

**SHEET NOTES**  
 FEATURE FILLET 0.125  
 FINAL MASS PROPERTIES:  
 MASS: 1.3980 POUNDS  
 CENTER OF MASS: X = 0.0000, Y = 0.0337, Z = 0.0186

**PROPRIETARY AND CONFIDENTIAL**  
 THE INFORMATION CONTAINED IN THIS DRAWING AND ANY RELATED MATERIAL IS THE SOLE PROPERTY OF ENTERPRISE DESIGN AND INNOVATIONS. ANY SHARING OF THIS INFORMATION, IN WHOLE OR ANY PART THEREOF IS PROHIBITED WITHOUT EXPRESS WRITTEN CONSENT OF ENTERPRISE DESIGN AND INNOVATIONS.

<b>SARRUS WHEEL</b>				REVISIONS DATE:	ITEM:	NAME	DATE	UNITS IN INCHES TOLERANCES ARE 0.010 INCHES UNLESS OTHERWISE NOTED
						DRAWN	CSS	
<b>SARRUS MECHANISM</b>						CHECKED	000	MATERIAL Aluminum Bronze
						APPV.	000	
<b>VARIOUS VIEWS</b>						VERSION DATE	10/10/2017	SHEET FILE NAME: 171010-2016-Sarrus-Wheel
SHEET <b>1</b>	SHEET SCALE <b>1:2</b>	SHEET SIZE <b>B</b>	REV					



4

3

2

1