

*SOLIDWORKS xDesign*

*YSWUG*

*November 7, 2018*

*PRESENTING...*

**A SNEAK PEEK @ XDESIGN:  
MILAN CHALLENGE,  
LIGHTHOUSE PROGRAM, &  
AWESOME FUNCTIONALITY**

*BY*

*ERIC A. BEATTY*

*SASPUG-NEWS@OUTLOOK.COM*

*TWITTER: @ERICBEATTY43*

*USER GROUP TWITTER: @SASPUG*

# ABOUT ME

- *Senior Mechanical Designer (2006-present)*
  - *Omax Corporation – Kent, WA USA*
- *Full-time Faculty/Dept Head (1994-2006)*
  - *Engineering Design Technology Program*
  - *North Seattle Community College*
- *Mechanical Design Professional since 1985*
- *SOLIDWORKS User since March 1996*
- *Founder of SASPUG – very 1<sup>st</sup> SOLIDWORKS User Group*
- *SOLIDWORKS Certifications:*
  - *CSWI - 1997*
  - *CSWP – Original Exam (2003) & 20<sup>th</sup> Anniversary Exam (2018)*
  - *CSWP Advanced Topics: Sheetmetal (2008), Surfacing (2014), Weldments (2015), Drawings (2016), Mold Tools (2017)*
  - *CSWE planned for prior to #SWW2019 (fingers crossed!)*



# MY MILAN CHALLENGE ENTRY... ...THE PERSONAL WATERJET

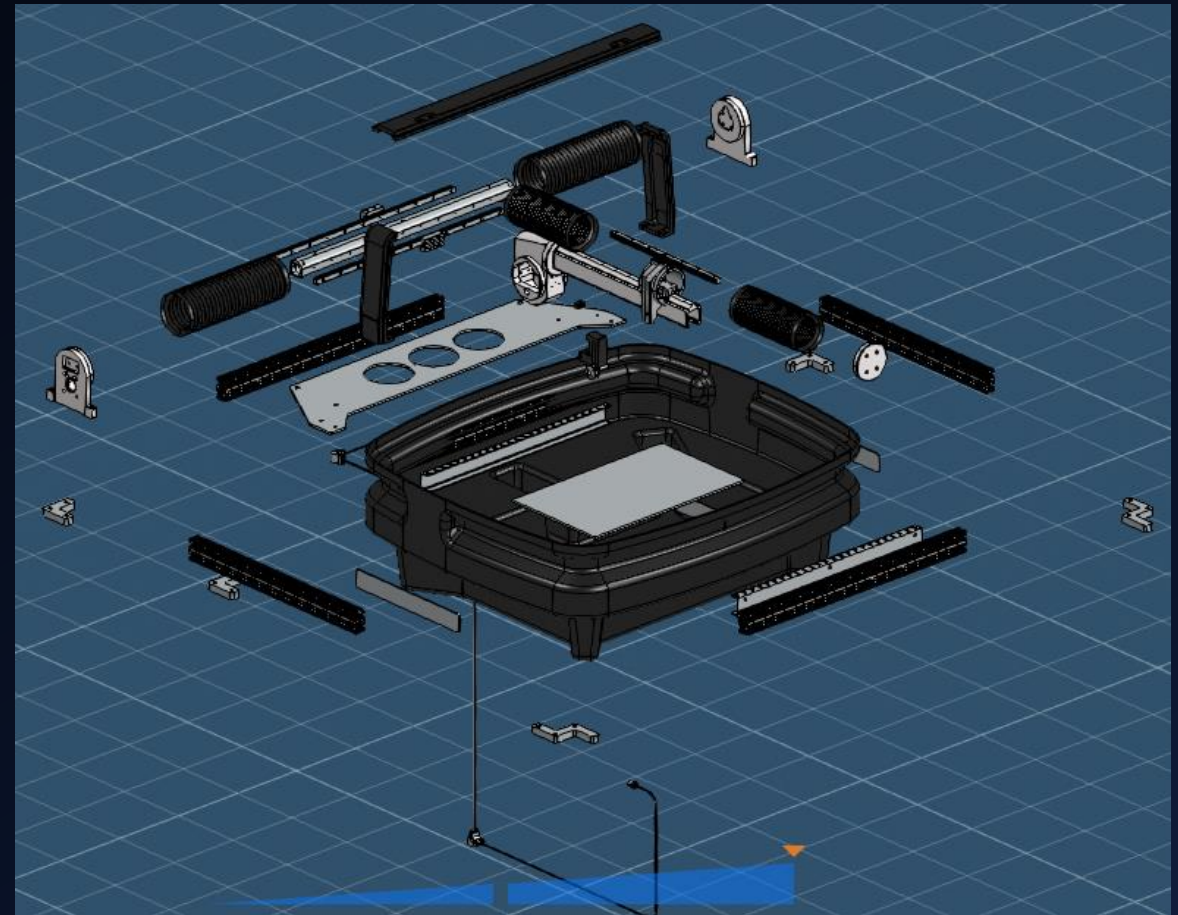
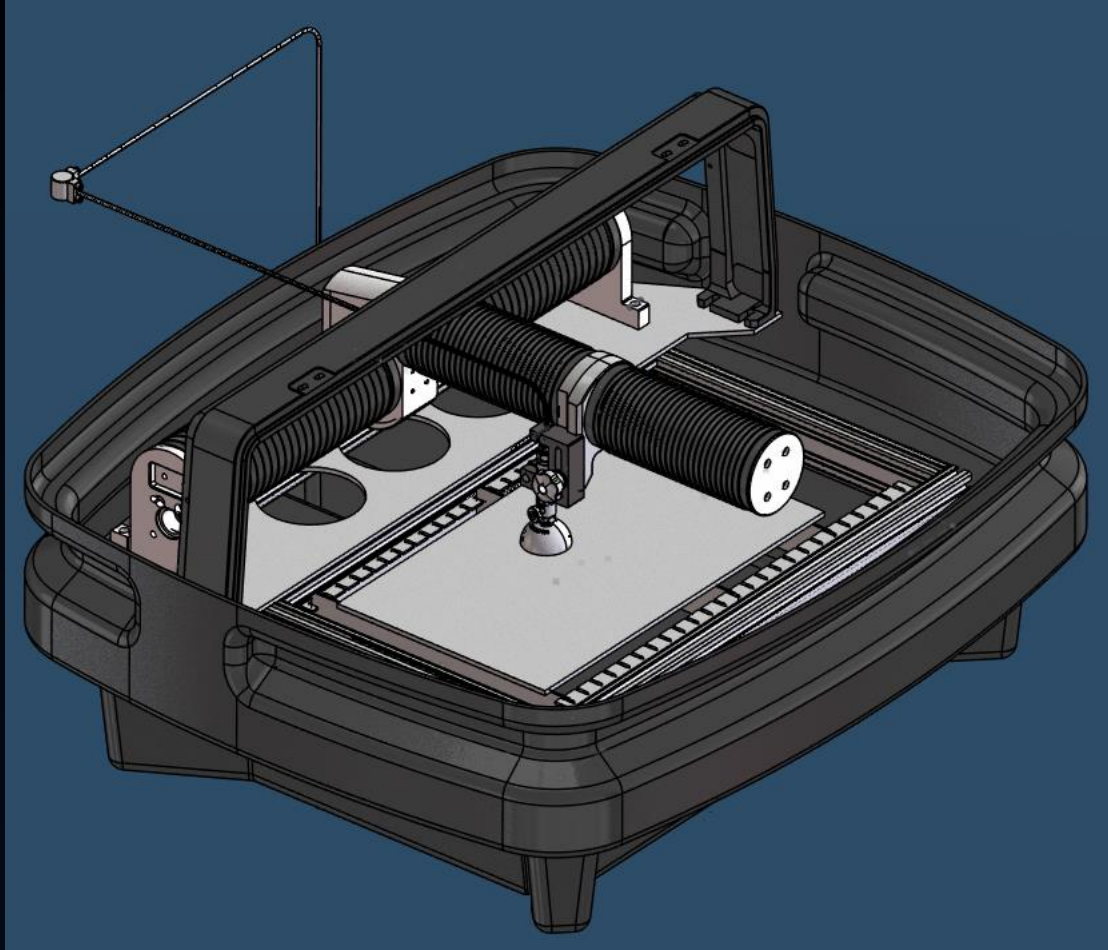

# SUMMARY STATISTICS

- Full blog article: <https://blogs.solidworks.com/solidworksblog/2018/05/eric-beattys-intro-to-solidworks-xdesign.html>
- ~36-40 hours of modeling time on multiple devices, including Amazon Fire tablet!
- 35 Components were modeled for this Assembly
  - 1 Top Assembly
  - 3 Unique Subassemblies
  - 31 Unique Part Models

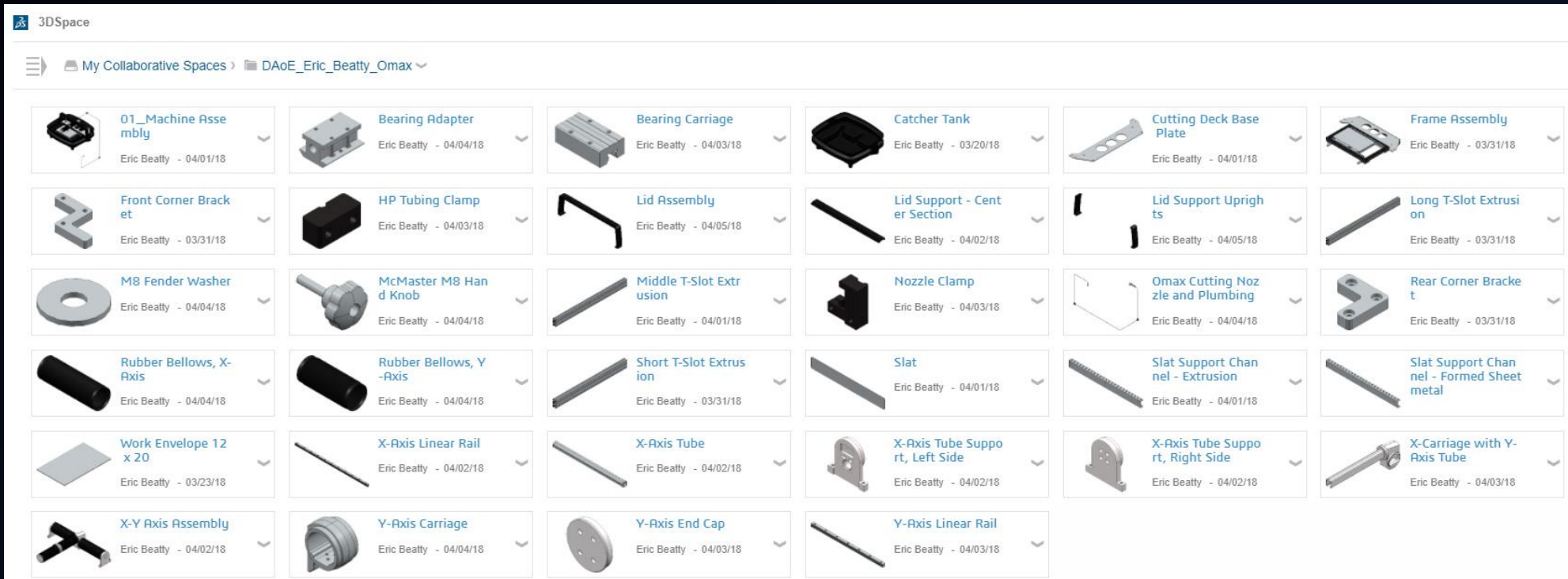

# THE MILAN CHALLENGE...

- *5 Designers, 13 hours, 1 common goal ...*
- *Here's a blog article about the challenge*
  - <https://blogs.solidworks.com/solidworksblog/2018/05/solidworks-xdesign-hackathon-in-milan.html>

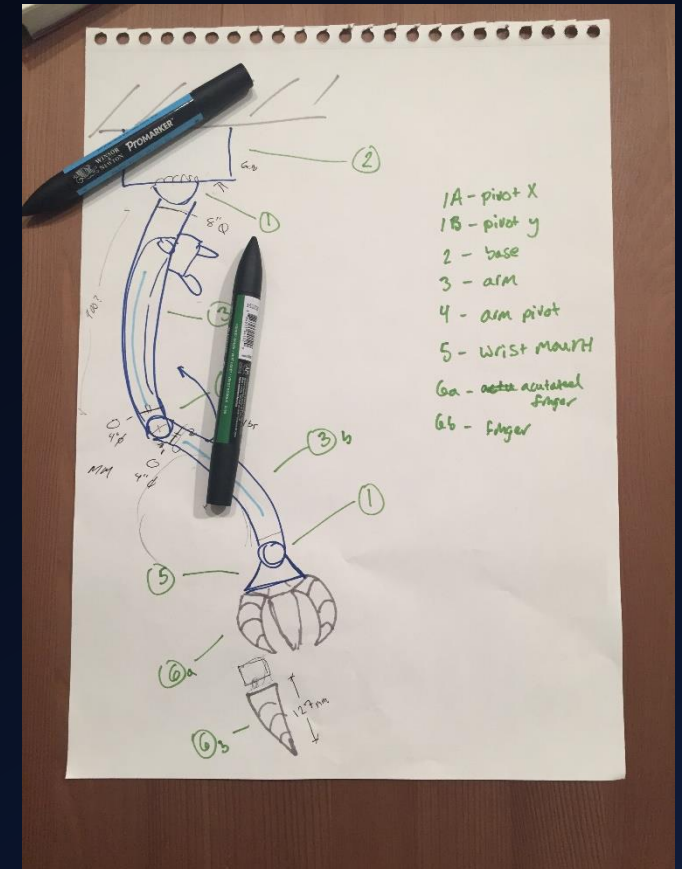

# OUR ROBOT...

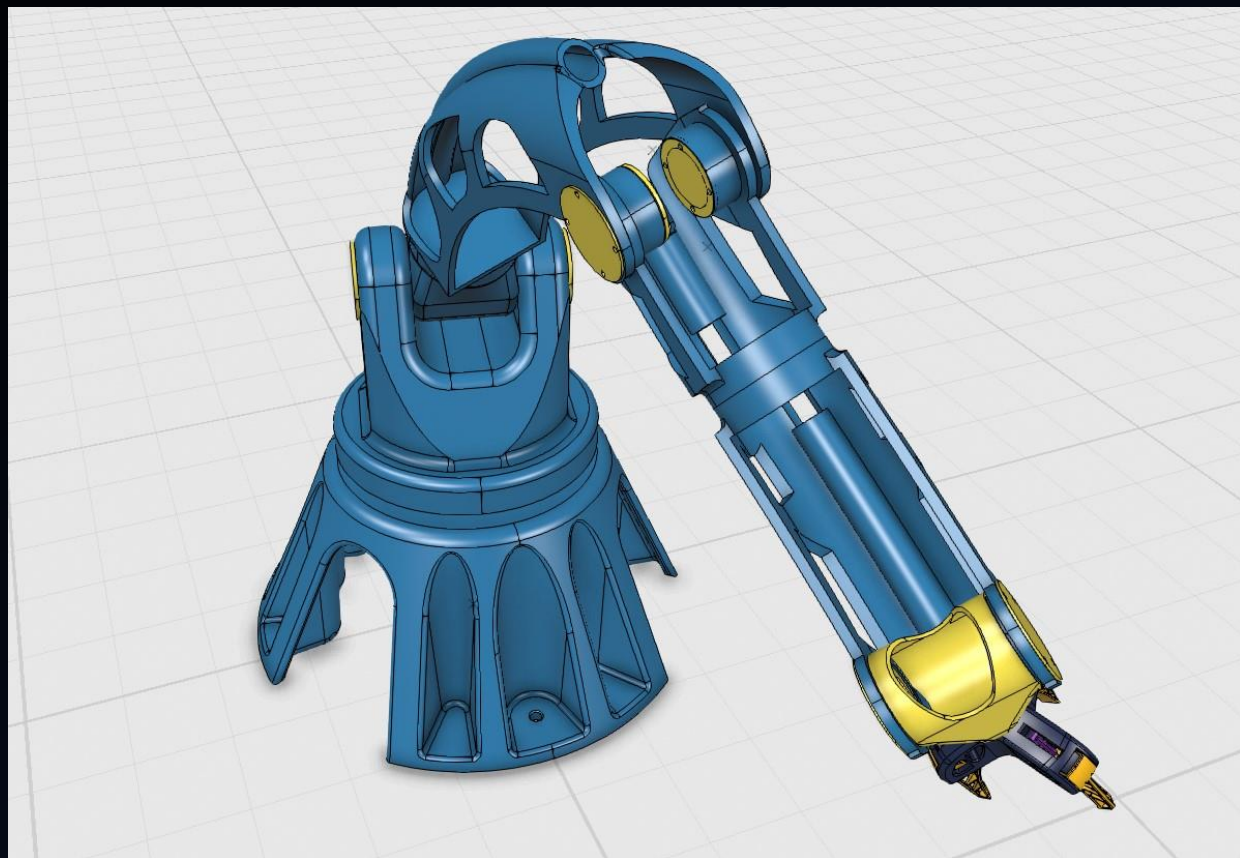

# HOW YOU CAN GET INVOLVED WITH XDESIGN...

- *The main webpage for xDesign is*
  - [xdesign.solidworks.com](https://xdesign.solidworks.com)
  - *The site features videos, case studies, blog entries, feature articles, etc.*
- *To join the Lighthouse program:*
  - <https://www.solidworks.com/how-to-buy/join-xdesign-lighthouse-program>
  - *A button/link to this is on the main xDesign website*
- *As a Lighthouse beta tester, you'll have direct tech support, provide valuable feedback, submit enhancement requests and guide the product's roadmap*
- *You'll have the opportunity to enter future design challenges with the possibility of prizes (trips to Italy NOT guaranteed! 😊)*

